

**TC 125 Tier 3
Terex Excavator
Installation Instructions**



PHONE: 1-800-267-2665

FAX: 1-888-267-3745

Evaporator/Heater Box

The evaporator / heater box is located under the operators seat in the same location as the original heater box. Air flow passes through the original louvers and defrost vents as well as two extra louvers mounted on either side of the operators seat.

Step: 1) Remove the operators seat from the cab by unbolting the metal plate that the seat sits on. Remove the four M8 bolts, two in front of the seat and two behind the seat. Lift the seat and plate out through the cab door. Remove the cover plate over the heater box by removing the rear two M8 bolts.



Remove seat and seat frame

2) Unbolt the original heater box from its frame. Keep the four M6 bolts for re-use. Clamp off the heater lines from under the cab and unplug the blower motor. Disconnect the heater lines at the heater coil and remove complete heater assembly from the cab.

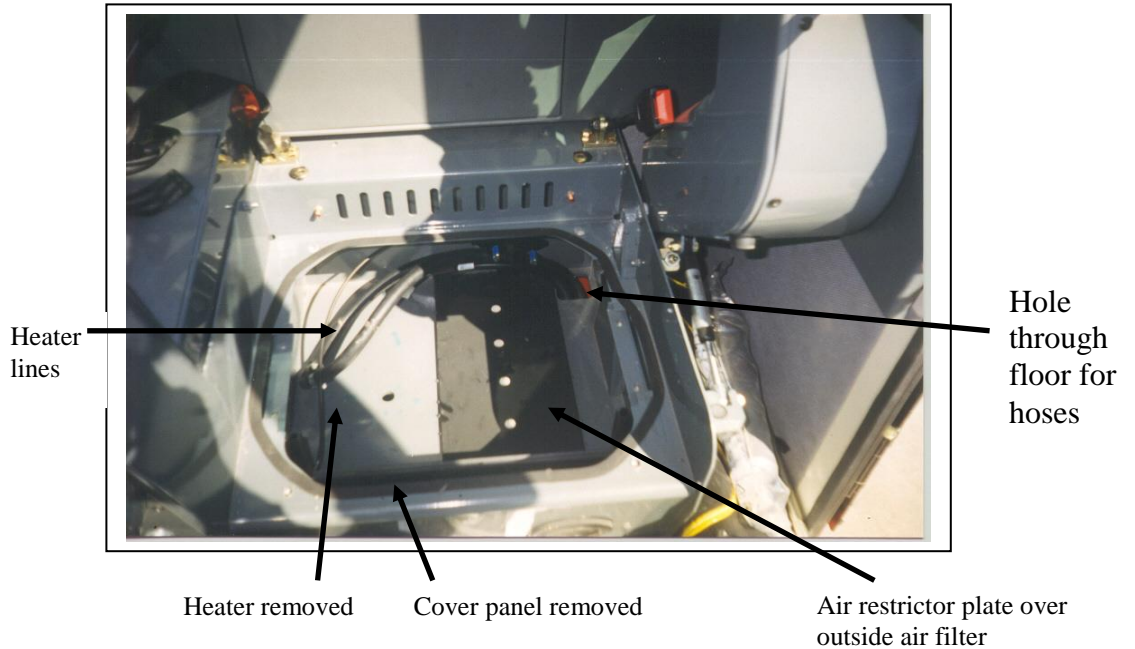

3) The outside air intake filter on this machine is much too large for the air conditioner to work effectively and must be restricted in size. Install the restrictor cover over the filter from inside the cab. Place the foam gasket down and secure in place using double sided tape or silicone.

4) Square up the rounded rear corners of the heater box opening using a jigsaw or sawsall. This makes enough room for the larger A/C heater box to slide in.

5) Connect the drain tube to the drain outlet on the fitting and of the box and then set the box half in place. Reconnect the heater lines to the heater outlets on the box. Route the drain tube through the hole in the floor beside the outside air filter.

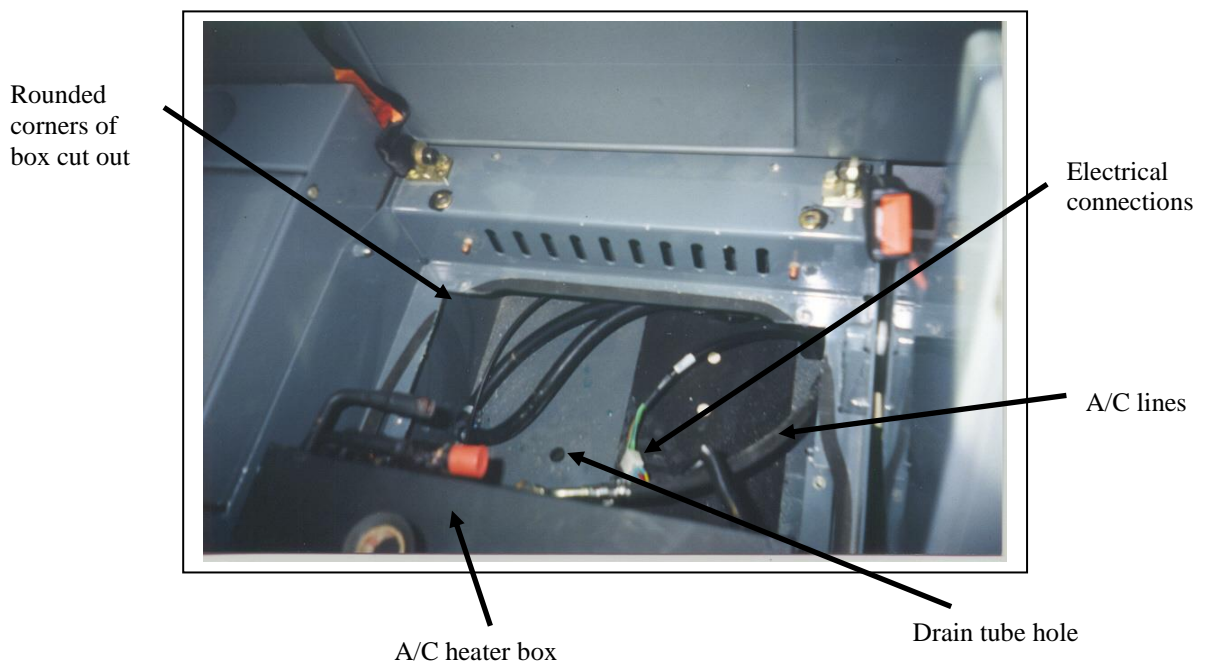

6) Once the A/C lines are run into the heater box area, the A/C lines can be connected to the fittings on the A/C heat box.

7) Plug the wiring coming out of the A/C heat box into the terminals from the original blower plug. Test the blower to ensure that the speeds are in the right order. When all the connections are done and tested on the back of the box, slide it back into place. Take care to pull any excess heater or A/C hoses down through the floor as the box is being slid into place. Place the box on the mounting bracket and bolt down in place re-using the M6 bolts.

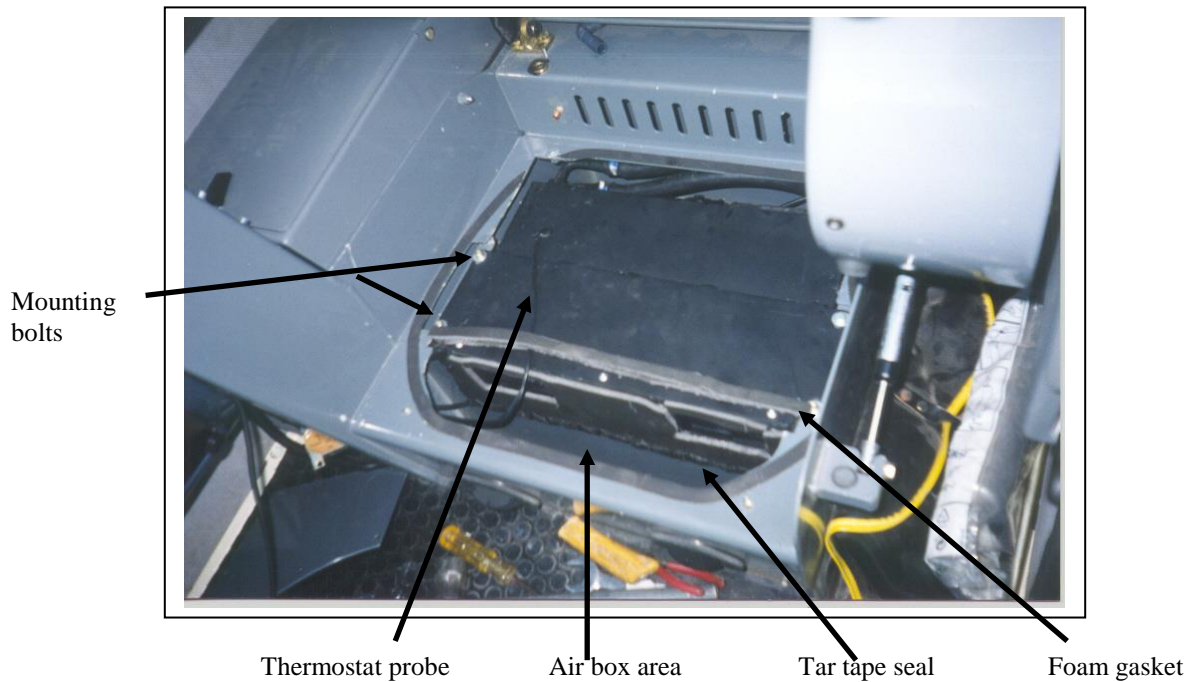

8) Use tar tape to seal the bottom and sides of the A/C heater box to its compartment so no air can escape around the bottom or sides of the box. This is done on the blower outlet of the A/C heater box.

9) Install the thermostat probe by sticking it into the predrilled hole in the top of the box about 5". Secure with a piece of tar tape.

10) Place a strip of foam across the top front edge of the A/C heater box so that when the cover plate is installed there is a sealed air box formed in front of the heater box.

11) Remove and discard the inside air re-circulation control plate. This is removed so an operator cannot accidentally block off the inside air supply.

12) Drill two 2 ½” holes in the cover plate so that the holes will be overtop of the air box area in front of the A/C heater box. Install the two 2 ½” hose adapters up from the bottom of the cover plate so that the 2 ½” flex hose can be installed on the topside of them. These hoses will supply the extra two louvers in the back corner of the cab.

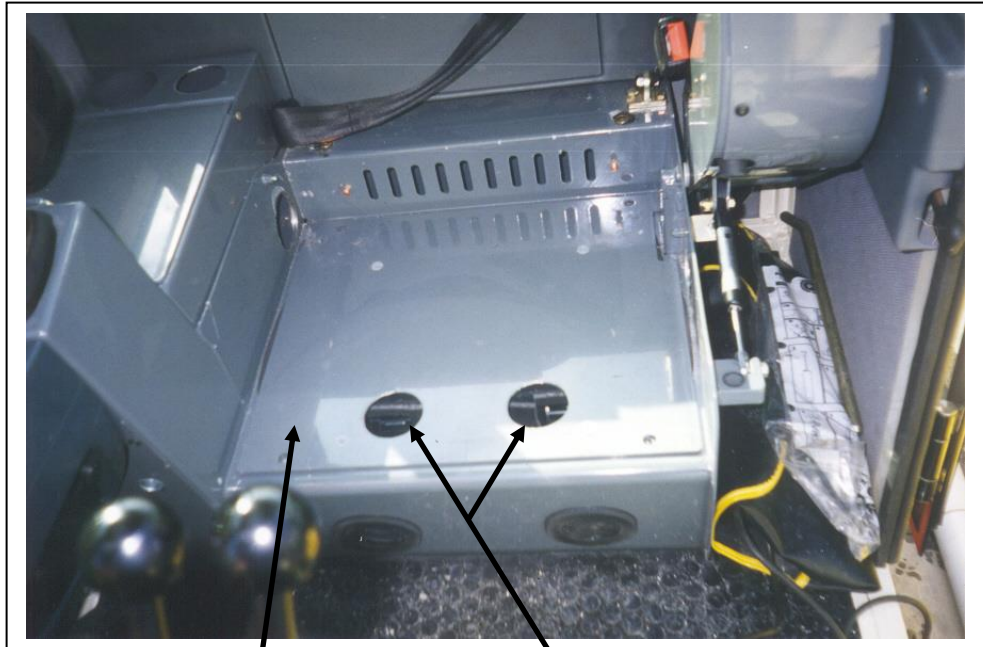

Cover plate

2 ½” holes for hose adapters

13) On the right side of the cab, drill a 2 ½” hole through both layers of metal in the right side storage compartment. The hole should be positioned on the side panel just above the cover plate and just ahead of the inside air intake area.

14) Drill another 2 1/5” hole just to the left of the drink holder at the back right corner of the cab. Run a 2 ½” flex hose from the right hose adapter through the 2 1/5” side hole and out the 2 ½” top hole. Cut it to length and connect it to the hose adapter on the round snap-in louvers supplied in the kit. Secure the hose with a tie wrap then snap the louver down into the hole.



2 1/5" hole for snap-in louver

2 1/2" hole for flex hose

15) On the left side of the cab, about 1" ahead of the left control arm pivot frame make a 2 1/2" hole just above the cover plate to pass the 2 1/2" flex hose through.

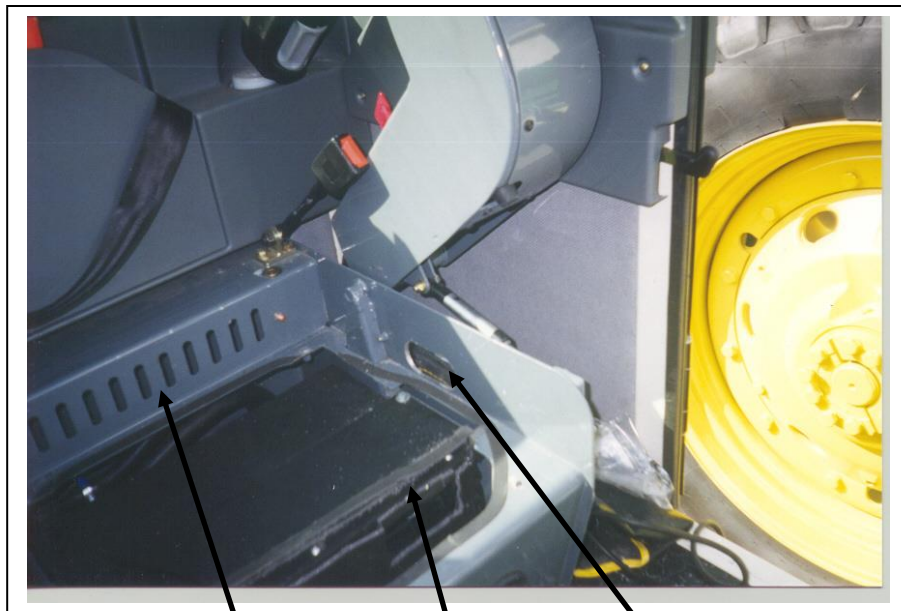

Inside air panel removed

Foam gasket

Hole for flex hose

16) Route the flex hose under and to the outside of the control arm and up behind it. Cut the flex hose to length and attach it to the hose adapter of the black ball louver. Mount the ball louver to the left cab wall using self drilling screws. Mount the louver bezzel just ahead of the windshield washer tank with the top of the bezzel about level with the top of the washer tank cover.

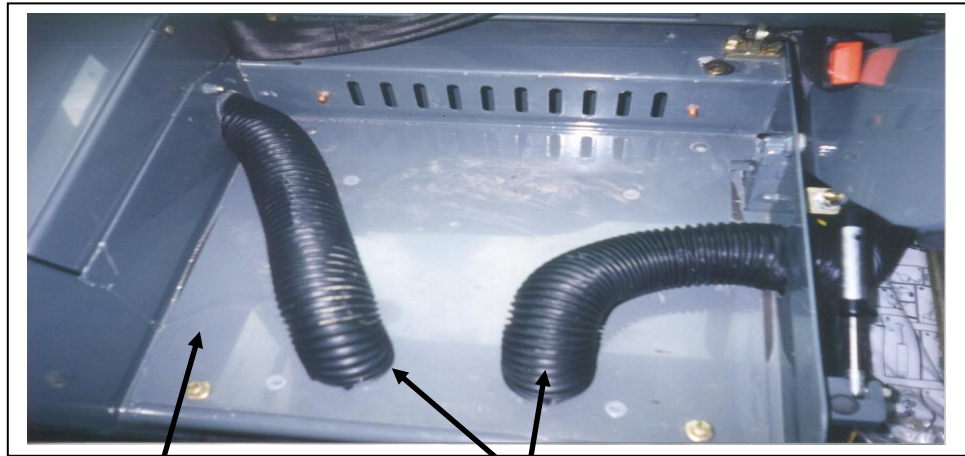

Cover plate

Flex hose attached and run

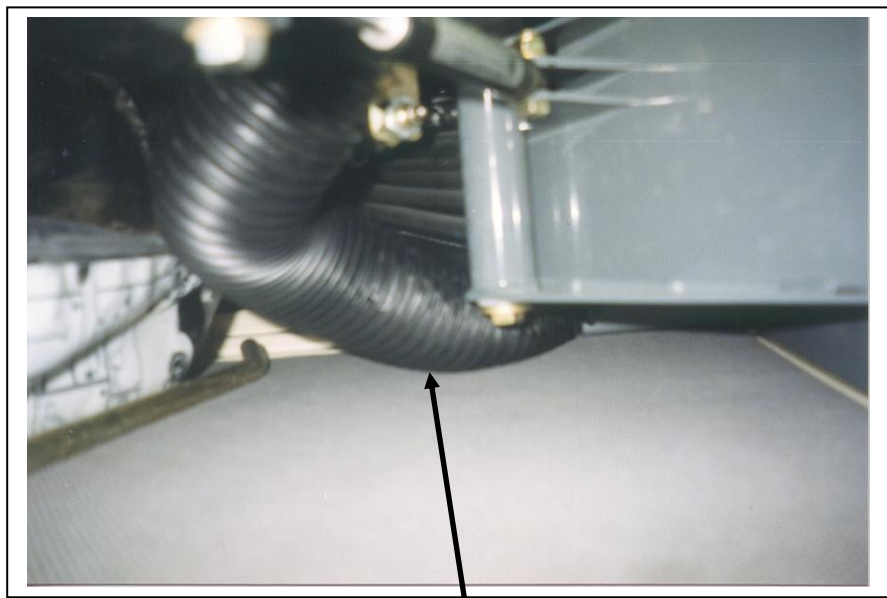

Flex hose under left control arm

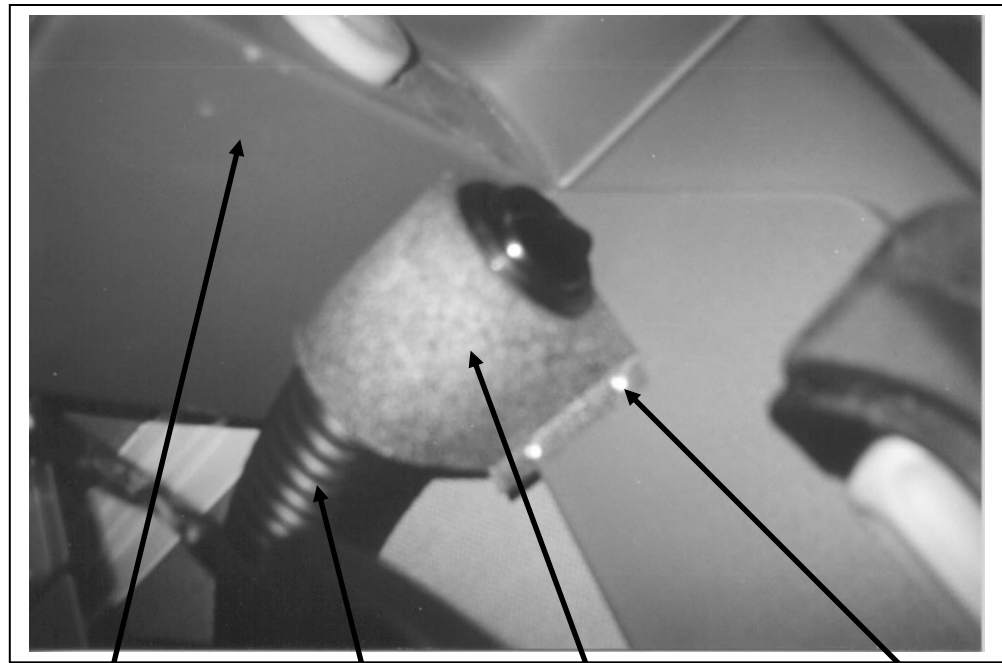

Windshield
washer tank

2 1/2" flex hose

Louver bezel

Self drilling screws

17) When the system is all installed and tested, the seat and mounting plate can be re-installed and all electrical access panels can be re-installed.

18) Use tar tape to seal the hole around the cab access for the heater and A/C lines. Also seal any extra space around the drain hole and install the drain tube restrictor in it.

Compressor Mount:

The compressor is mounted on the top right corner of the engine and is driven off the engine crank.

STEPS:

- 1) Unbolt the top radiator support bracket from the engine and from the rubber isolator. This bracket is not re-used.

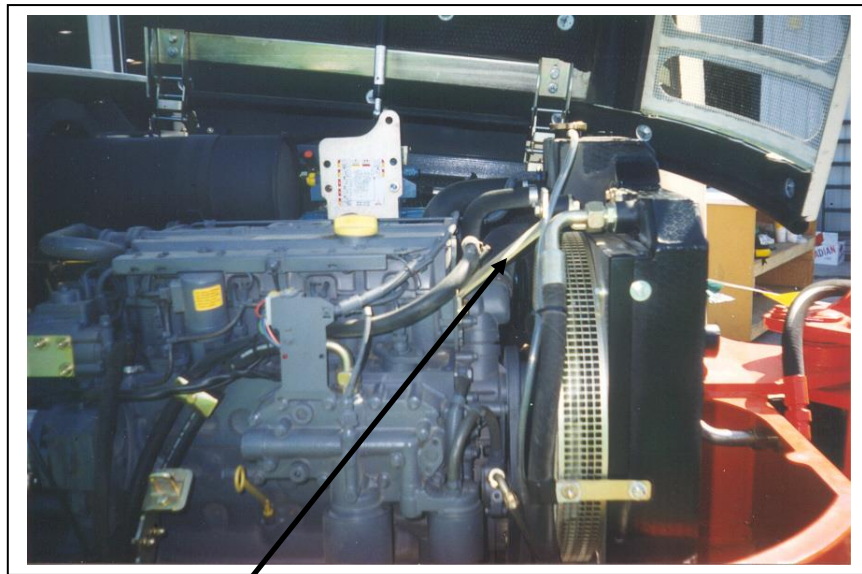

Remove support bracket and
isolator

- 2) Remove the fan shroud and keep. It will have to be modified to fit back on.

- 3) Bolt the compressor mount bracket to the engine head on the right side of the engine. Use four M10 X 30MM bolts to secure the mount bracket to the four threaded holes in the head.

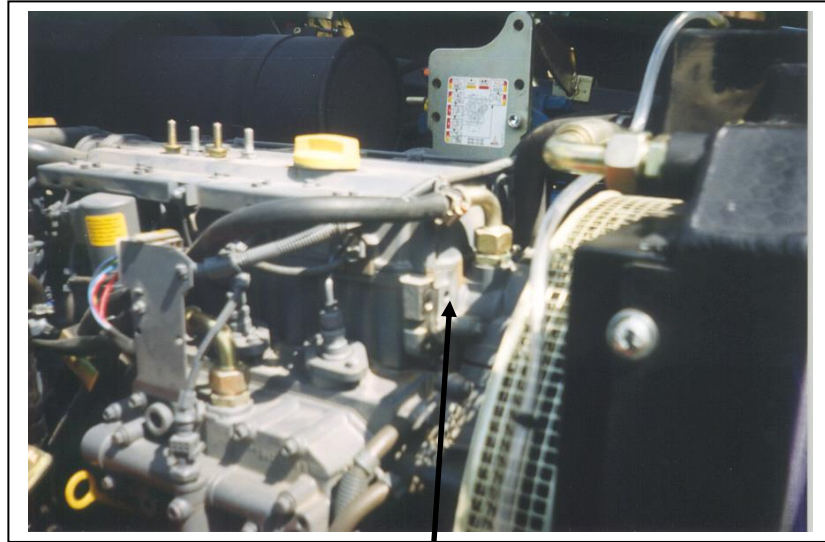

Four mount holes for compressor mount

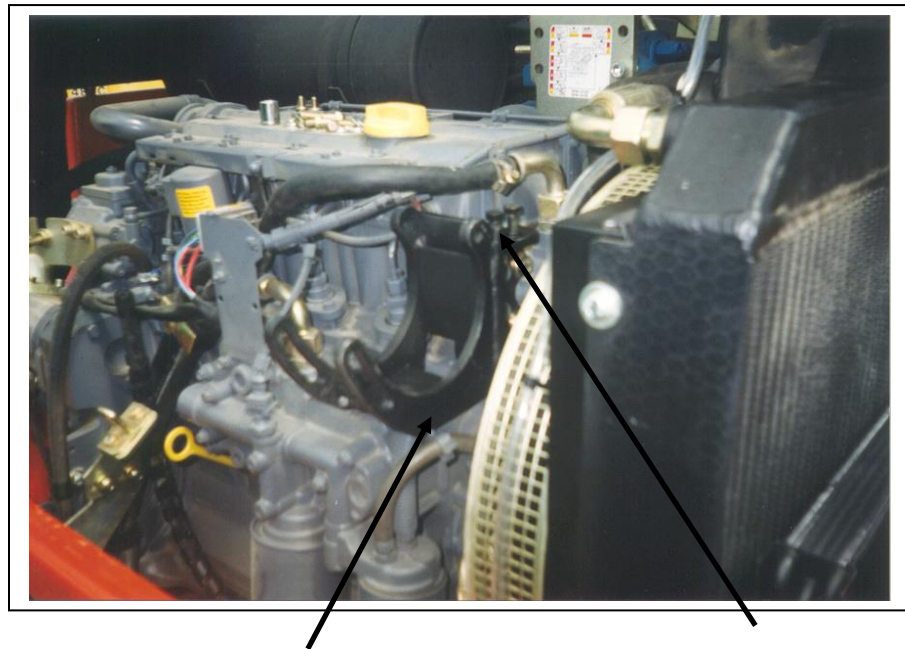

Compressor mount in place

Radiator support bolts here with two 3/8"x1" bolts, flat washers and lock washers.

4) Install the compressor onto the mount with the oil fill plug on the compressor at the top. Loosely bolt in place using the 3/8" X 1 1/2" hardware provided.



Radiator support bracket.

- 5) Install the 17660 "V" belt onto the compressor, fan, crank pulley and fuel pump. Tighten the compressor to tension the belt and secure all bolts. Double check the belt alignment and make all adjustments necessary.
- 6) Install the new upper radiator support bracket onto the two 3/8" threaded holes on the compressor mount bracket.

- 7) Double check that all of the hoses, wiring, fans and belts are clear of obstructions and secure from damage. Recheck all bolts and belt alignment.



Compressor in place with guard in place. Modifications to the belt and fan guard are required to install the compressor.

Condenser

The condenser mounts to the intake side of the radiator down on the lower half of the radiator. This allows the sloped engine cover the maximum clearance.

- 1) Remove the lower two M8 bolts from the sides of the radiator frame. These bolts hold the fan shroud onto the radiator frame.

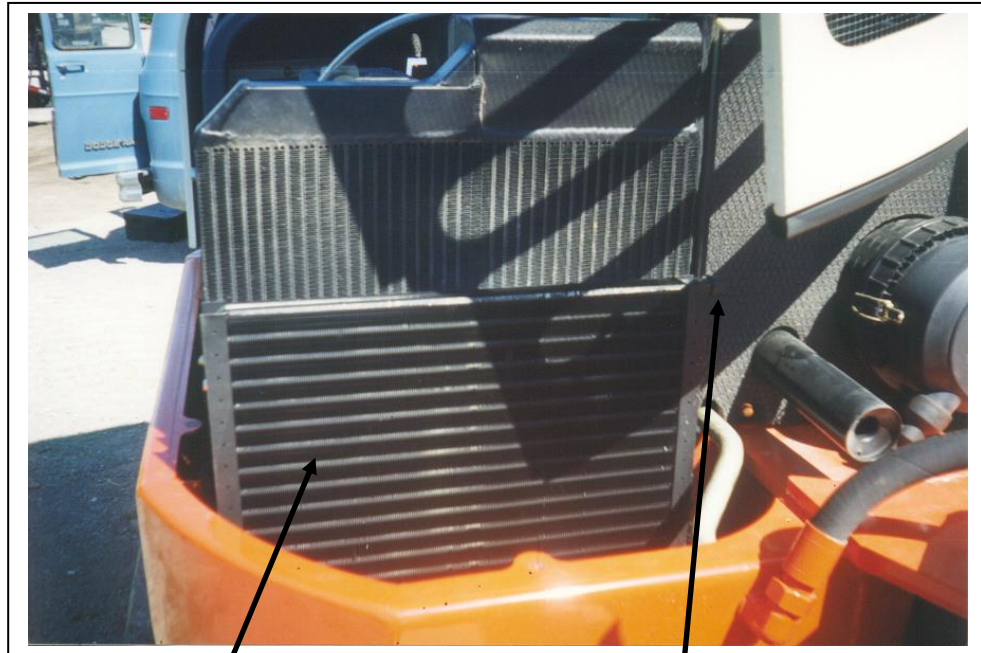

Condenser

13/32" fitting

- 2) Slide the condenser down into place until the slotted holes on the condenser line up with the threaded mount holes of the removed bolts. Re-install the bolts to secure the condenser in place. The fittings on the condenser are located on the cab end of the radiator. The mount bolts on the cab side of the radiator can be accessed by reaching overtop of the engine and from underneath the engine. The condenser mount brackets can be slid between the rubber sealing grommets and the radiator frame.

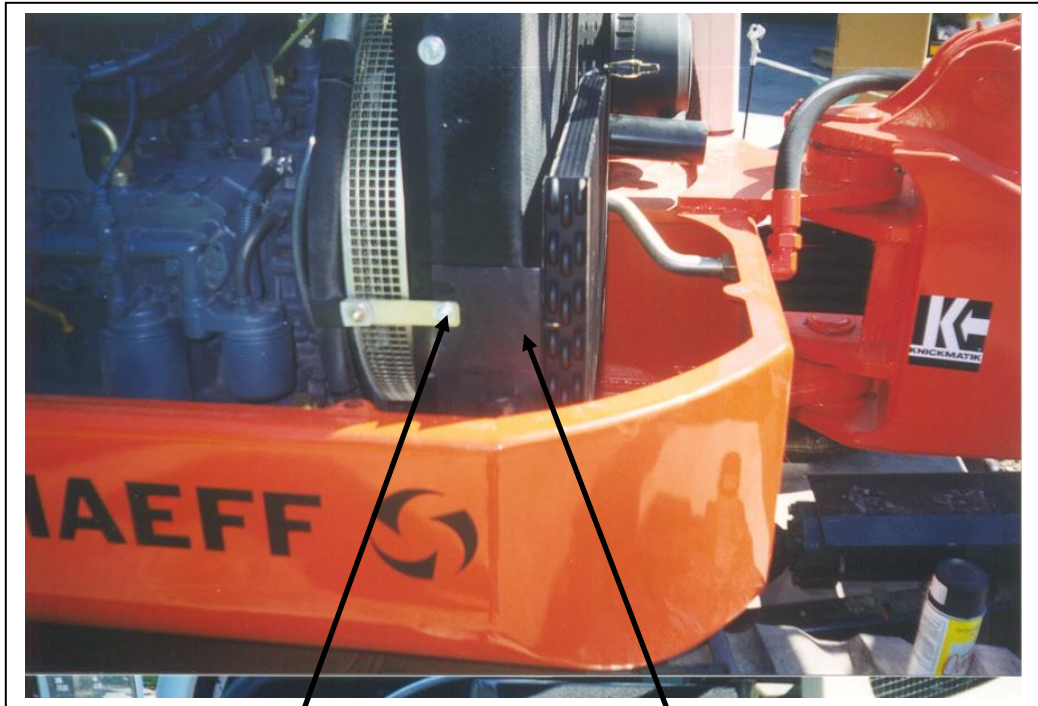

Top mount bolt

Condenser mount bracket

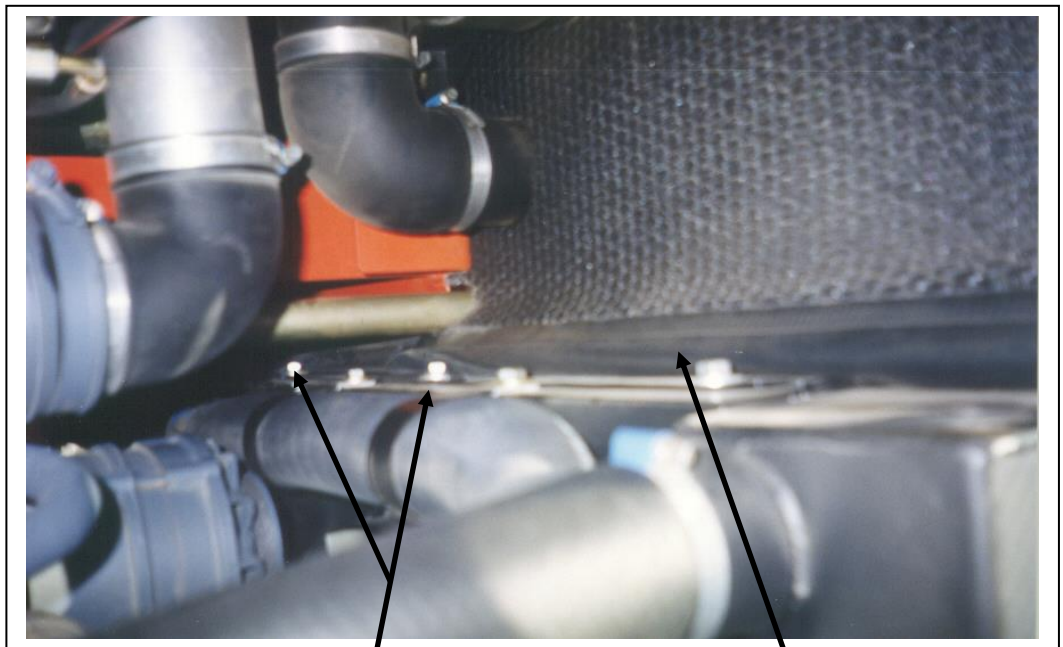

Two mount bolts for cab side of condenser mount bracket

Rubber sealing strip

Receiver Drier

The receiver drier is located on the cab side wall of the engine compartment just to the right of the hydraulic valve assembly.

- 1) Locate the M8 threaded hole on the cab side of the engine compartment frame. It should be down about six inches from the top frame rail between the hydraulic valve assembly and the air cleaner. If the hole is not there one will have to be drilled and tapped for an M8 bolt.

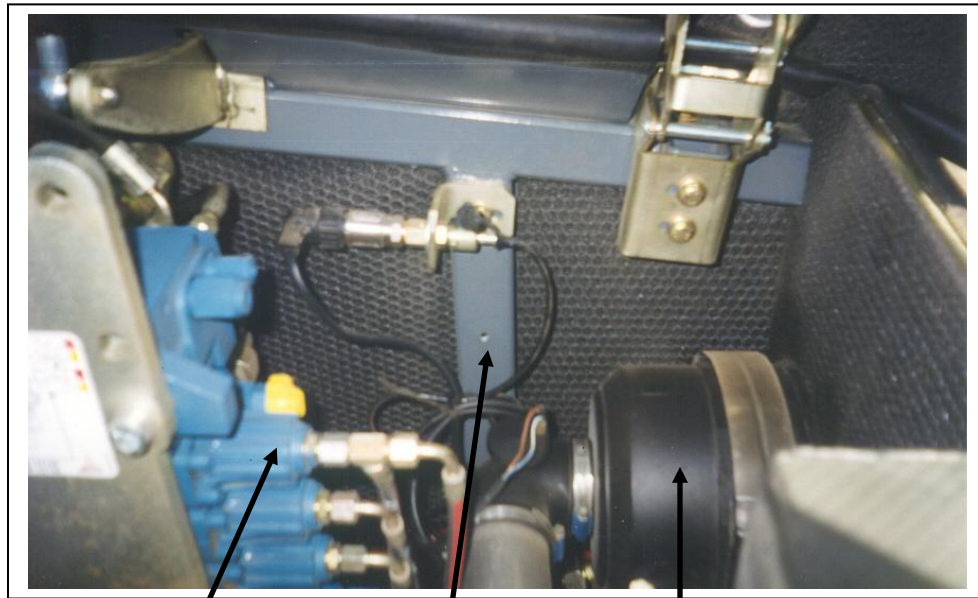

Hydraulic valve assembly

M8 threaded hole to mount drier bracket

Air cleaner

- 2) Bolt the “L” shaped bracket to the hole using the M8 hardware supplied.

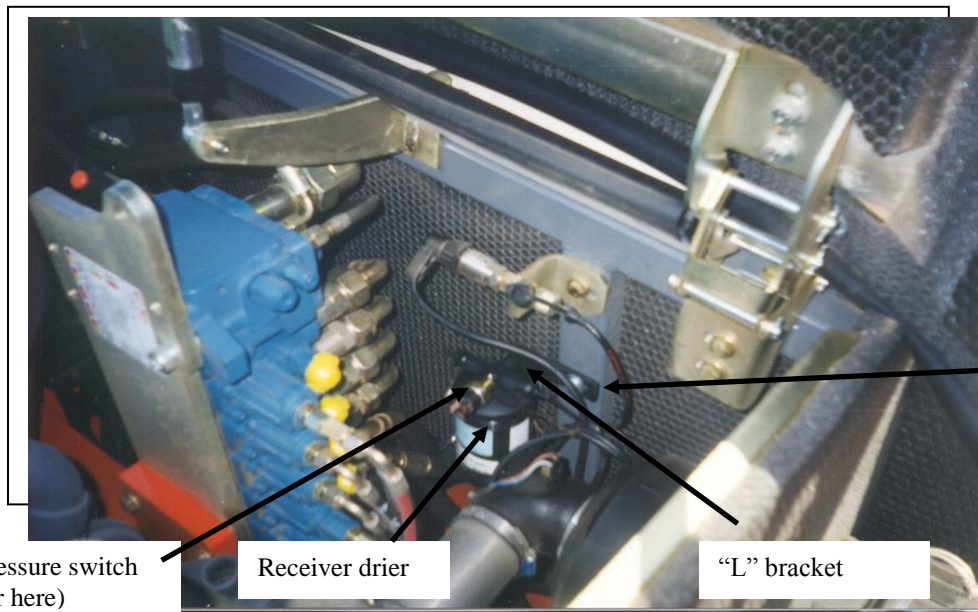

Binary pressure switch (no longer here)

Receiver drier

“L” bracket

M8 mount bolt

3) Clamp the receiver drier to the bracket using the two #48 gear clamps provided. The binary pressure switch is no longer on the drier. It is now mounted at the compressor.

Electrical:

The electrical system for this machine uses a rotary thermostat to control the system.

Steps 1) Mount the rotary thermostat in the side of the control panel. Carefully drill a 7/16" hole on the side of the control panel to mount the thermostat.



Drill a 7/16" hole and mount the thermostat here. Run the thermostat probe down towards the floor and into the heat/cool box area through the existing hole for the heater control cable.

Cut the small wire and splice the inline ATO fuse holder onto it. The correct small wire on the switch is double connected into one of the terminals on the blower switch with a heavier gauge wire. Check to ensure it has full power on all speeds.

2) Pass the thermostat probe through into the heater box area through the same hole as the heater control cable

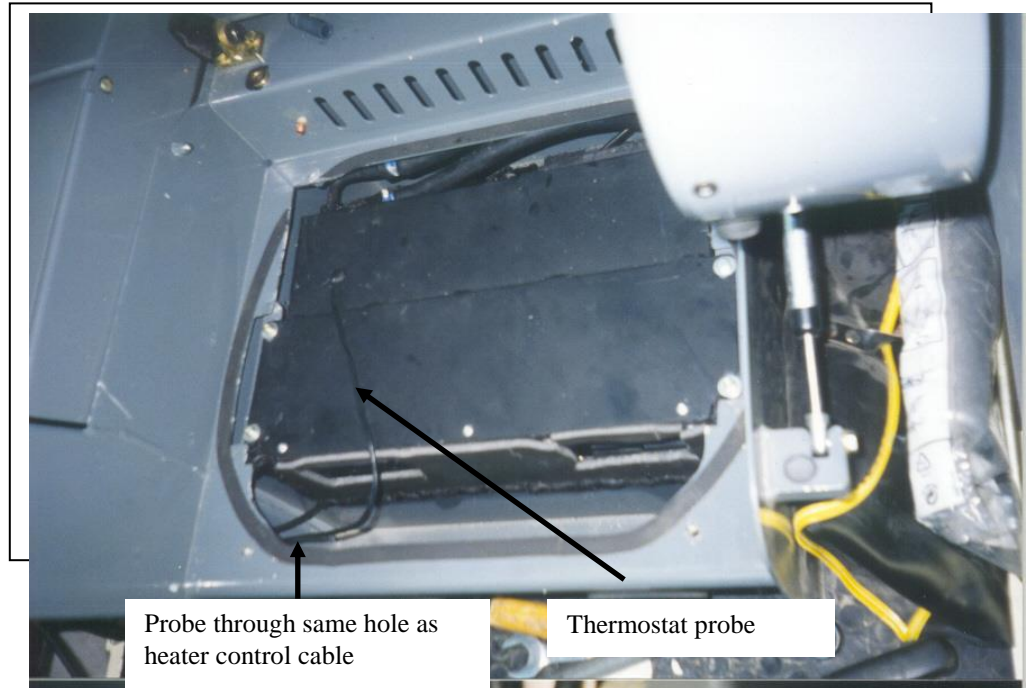

3) Draw ignition live power for the A/C system from the live female plug on the empty relay spot behind the plastic triangular cover on the side of the right control console. Crimp a bare male quick disconnect terminal to one end of the in-line ATO fuse holder. Insert that into the live female plug. Install a 7.5 Amp ATO fuse into the holder.

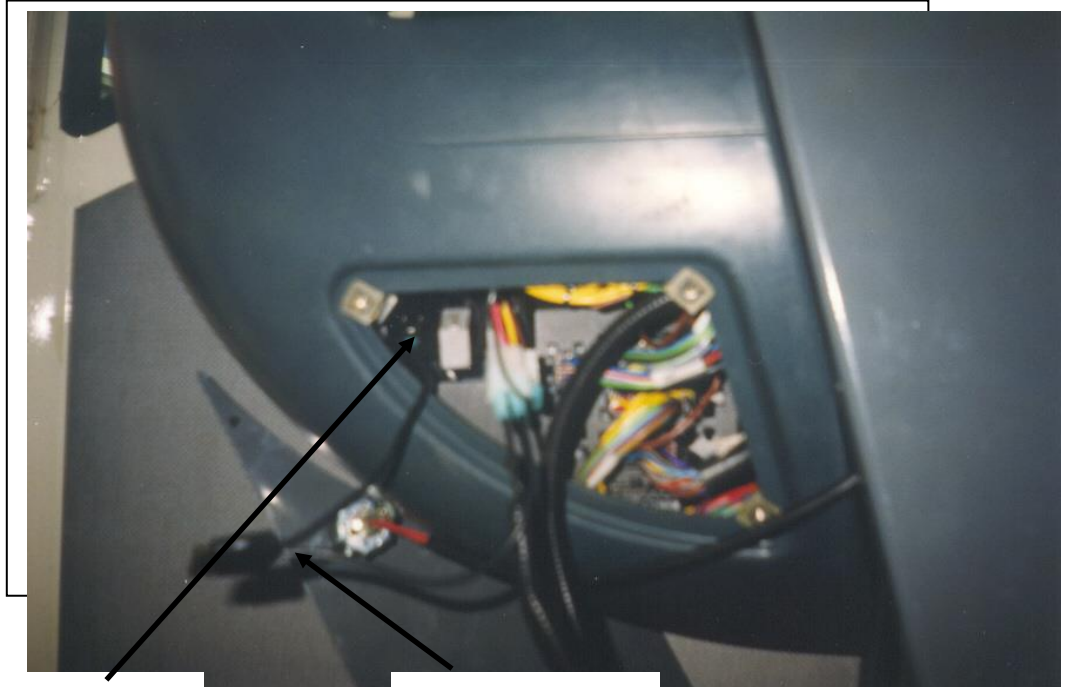

Ignition live 12 volt power

Inline ATO fuse holder

- 4) From the other terminal on the push button switch, run a 14 gauge black wire down to the thermostat and connect it to one terminal there.
- 5) From the second terminal on the thermostat run the long 14 gauge black wire in loom down through the floor and along under the cab with the A/C hoses to the compressor.
- 6) Cut the wire to length and crimp female quick disconnect terminals to the ends of both wires. Plug them into the two terminals on the binary switch mounted at the compressor. It doesn't matter which wire goes on which terminal.
- 7) Cut to length and connect it to the clutch wire on the compressor.
- 8) Replace the factory blower fuse with a 25 amp ATO fuse supplied.
- 9) The new A/C heat blowers draw more current than the original heater. This can cause the factory blower switch to overload when the blowers are on high speed. To eliminate this problem a relay is cut into the high speed blower wire coming from the blower switch. See the supplied drawing for exact instructions. Tuck the wired relay in with all the other wiring and reinstall the switch plate in the dash.

TC125 Tier3 Wiring Diagram

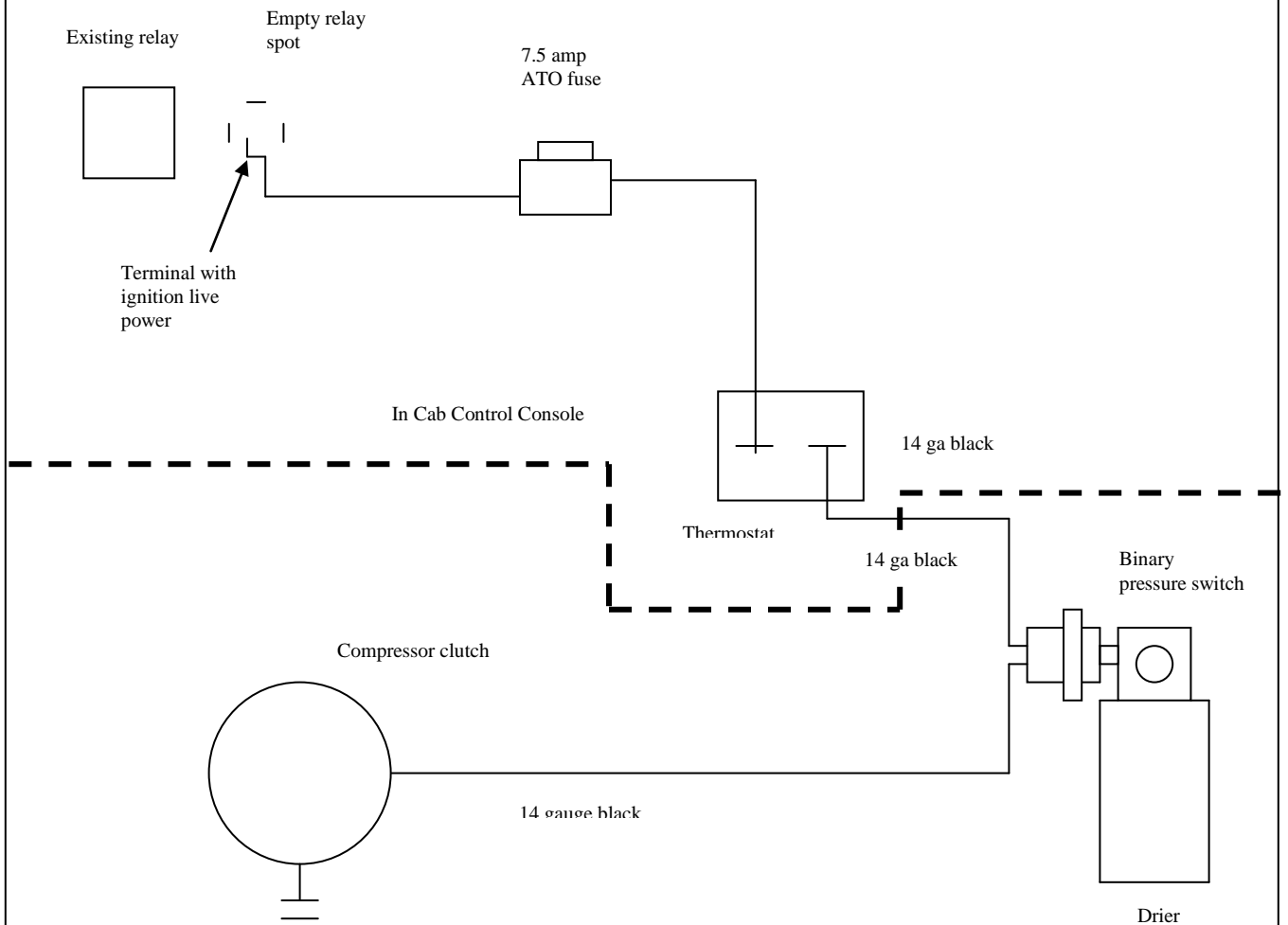

HR 20-32-42 HIGH SPEED FAN RELAY SETUP

CUT HIGH SPEED BLOWER WIRE 3" FROM SWITCH AND CRIMP
A BLUE FEMALE Q.D.T. ON BOTH SIDES OF THE CUT.
PUT 3" WIRE FROM SWITCH TO RELAY TERMINAL 86
PUT HIGH SPEED WIRE TO BLOWERS ON RELAY TERMINAL 87

FEB. 16, 2004

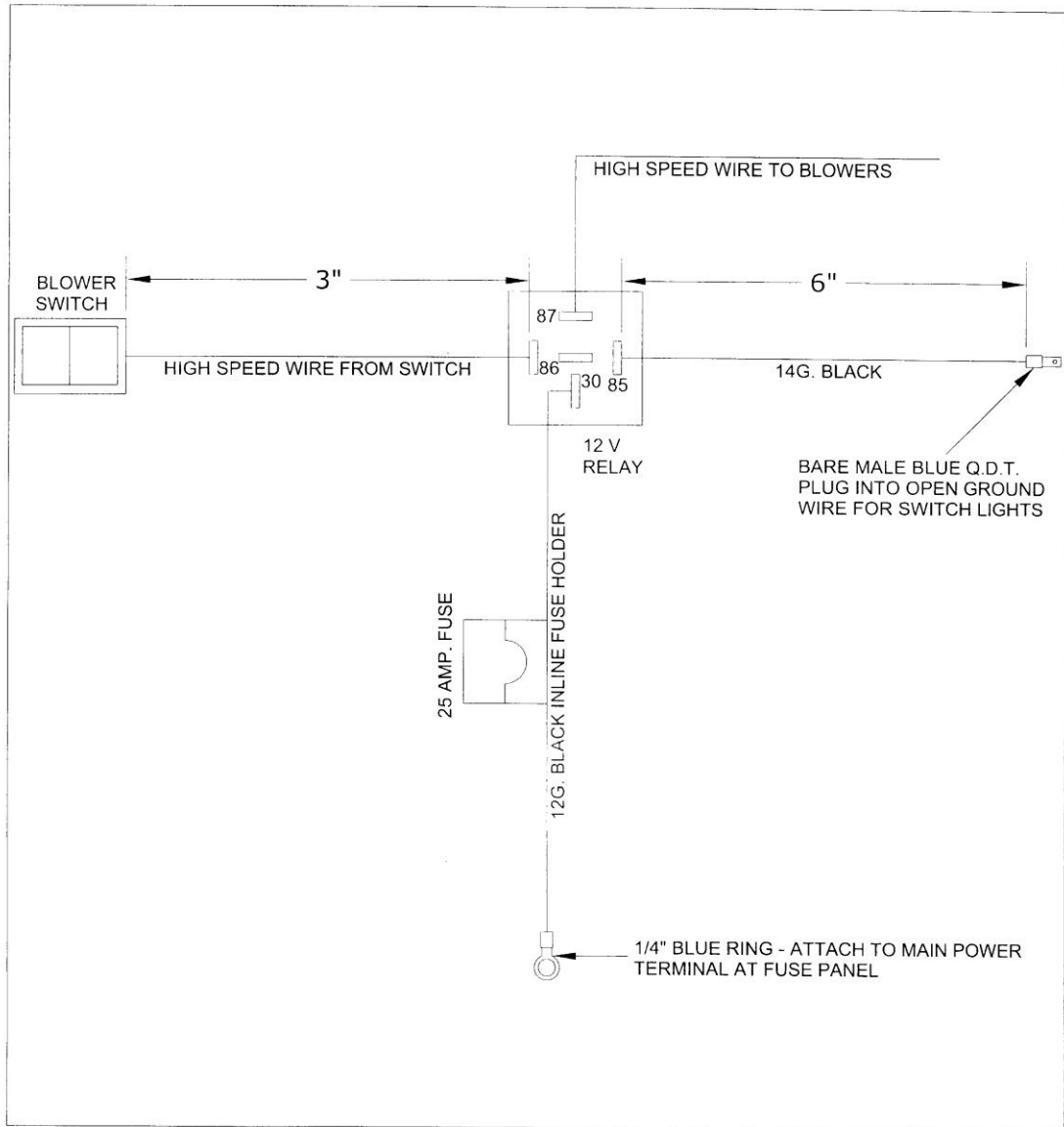

Hose Runs:

The A/C hoses connect all the major components of the system together. This system uses special A/C hose made by Aeroquip that has a reduced outside diameter and is very flexible. The hose fittings do not require a mechanical crimp but are attached to the hoses with special locking clamps. To install these clamps a special in-expensive pliers-like tool is needed.

STEPS

- 1) Starting at the compressor, the horizontal “O” ring pad fitting needs to be installed with the pressure switch to the compressor. Use PAG oil to oil the contact surfaces.



Horizontal “O” ring pad fitting and pressure switch attached to back of compressor.



A/C hoses and clutch wire

- 2) From the 1/2" (inner) fitting at the compressor, attach the straight fitting with the R134 charge port on the 1/2" hose to it using the correct "O" ring. Oil all contact surfaces with PAG oil. Route this hose back along the engine and down underneath the engine just behind the oil dipstick. This follows the heater hoses. Continue following the heater lines into the space underneath the cab. Run the 1/2" line over to the square hole in the floor just beside the back corner of the outside air filter. The heater lines also pass through this hole. Run the 1/2" hose up through the floor and over to the outlet fitting on the A/C coil. Connect the straight fitting to the A/C coil outlet using the correct "O" ring. Use PAG oil on all "O" rings and contact surfaces before assembly.

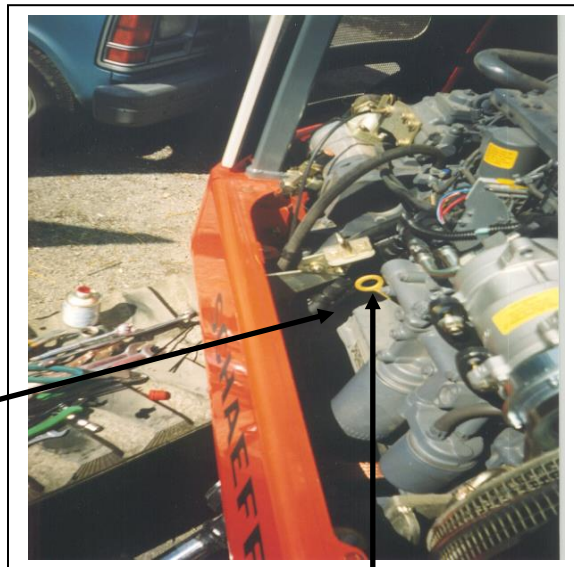

A/C hoses routed under engine

Dip Stick

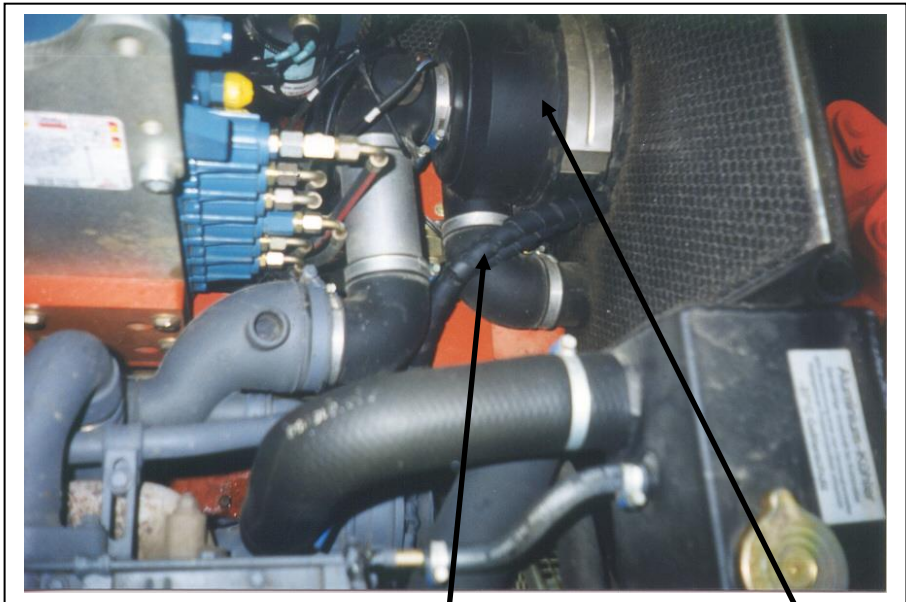

13/32" and 5/16" hoses

Air Cleaner

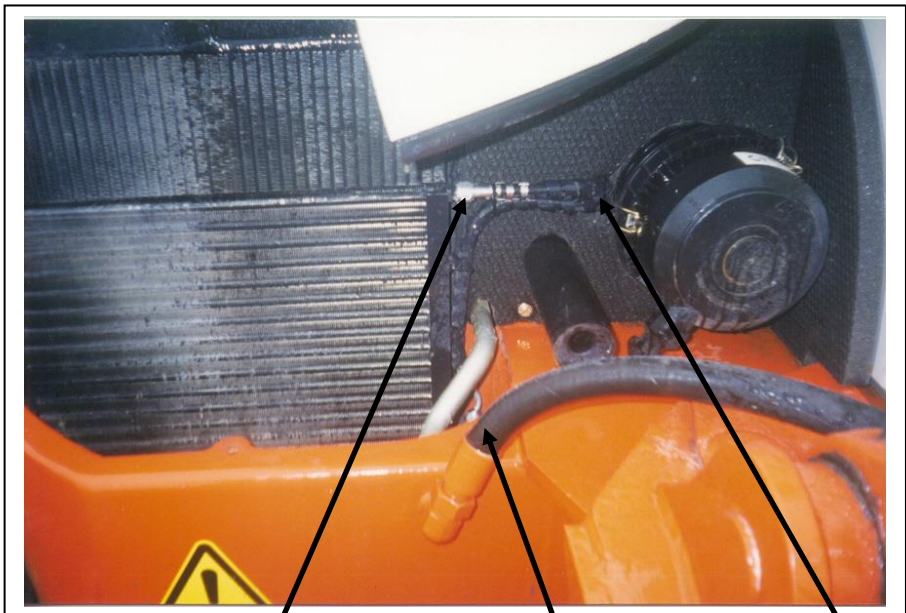

13/32" straight fitting

5/16" straight fitting

A/C hoses

- 3) From the 13/32" (outer) connection on the compressor, attach the straight fitting with the R134 charge port on the 13/32" hose to it using the correct "O" ring. Follow the heater lines and the 1/2" hose down under the engine and over the cab wall. At that point run the 13/32" hose to the right, up towards the side of the radiator. Route the hose through the wall beside the radiator by running it beside the air cleaner. Connect the 13/32" fitting to the top fitting on the condenser. Use the correct "O" ring and oil all contact surfaces with PAG oil.

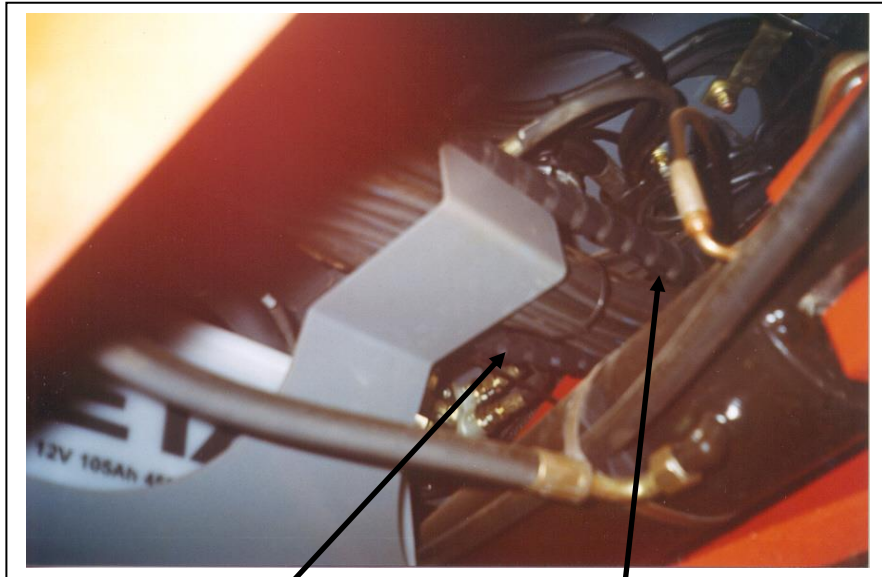

5/16" hose

1/2" hose

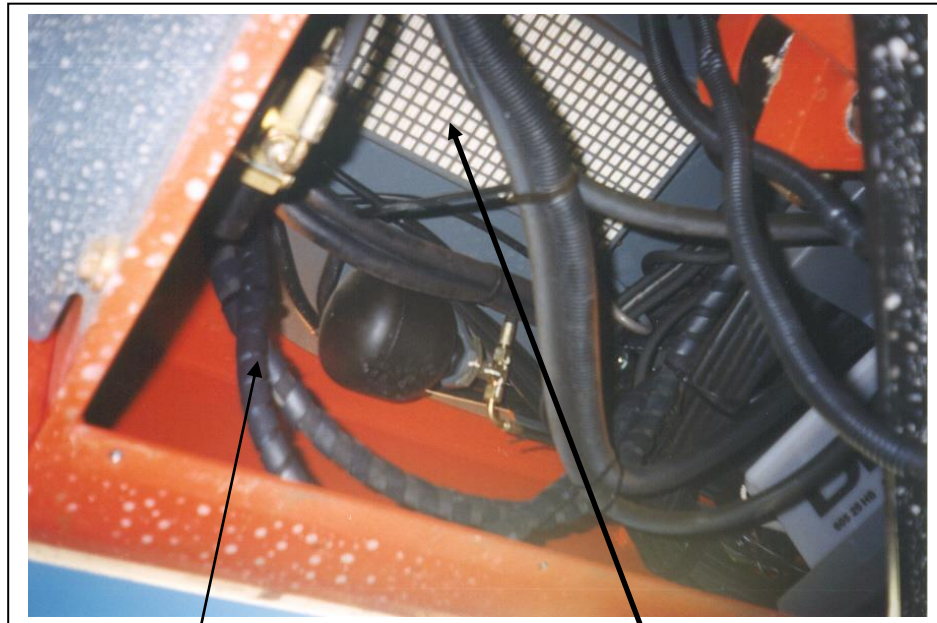

A/C Hoses

Outside Air filter

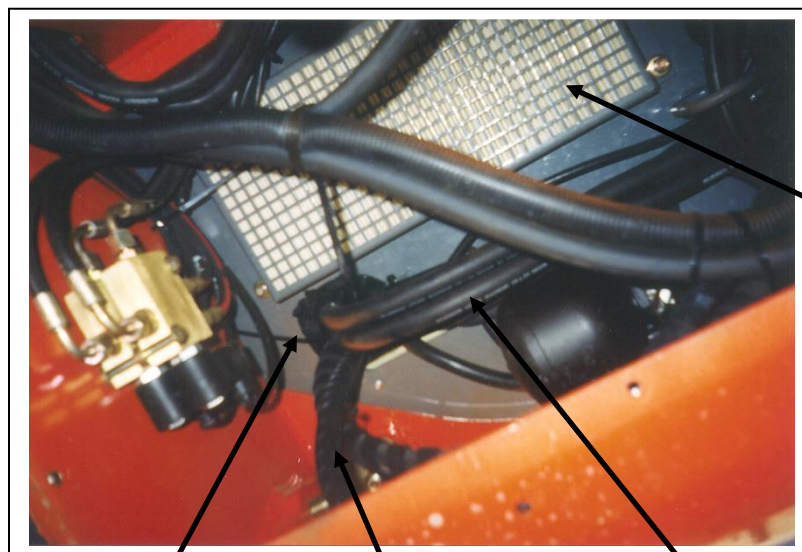

Hole in floor

A/C hoses

Heater lines

Outside air filter

- 4) At the lower fitting on the condenser, connect the 5/16" straight fitting on the shorter 5/16" hose to it. Route this hose along with the 13/32" hose through into the engine compartment. Split the 5/16" hose off from the 13/32" hose and run it up to the inlet port on the receiver drier. Connect the 90o on the 5/16" hose to the drier inlet. Use the correct "O" ring and oil all contact surfaces with PAG oil.

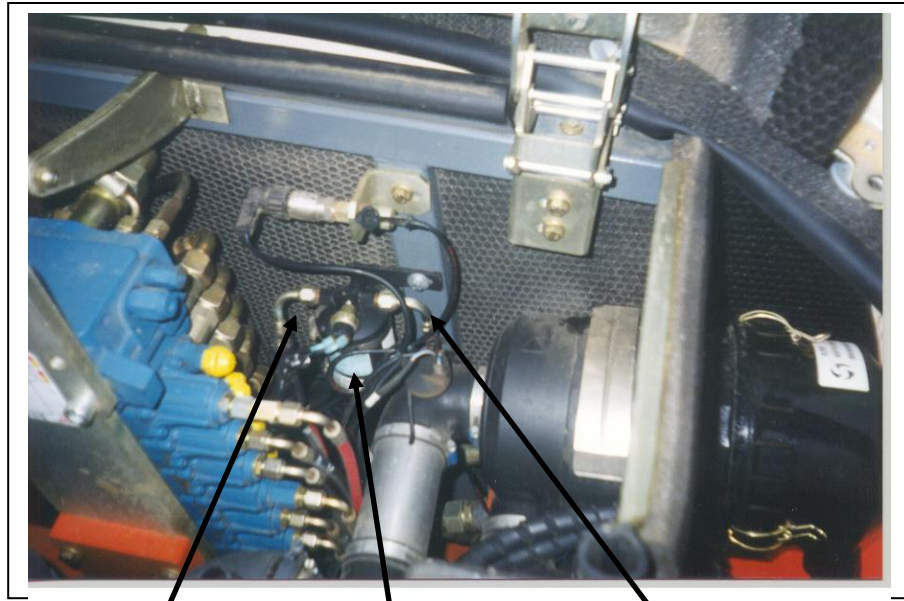

Outlet 5/16" 90o fitting

Receiver Drier

Inlet 5/16" fitting

5) Fr
Us
hos
1/2"
thro
to t
cor

to it.
ite the
h the
hose up
6" hose
e the

Blower
Electrical
plug

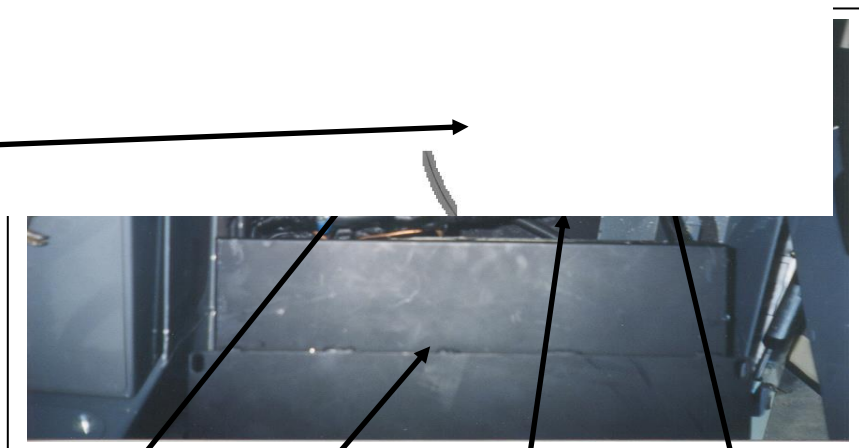

Heater lines

AC/ Heater box

1/2" A/C hose

5/16" A/C hose

Refrigerant Flow Pattern in a Standard Air Conditioning System

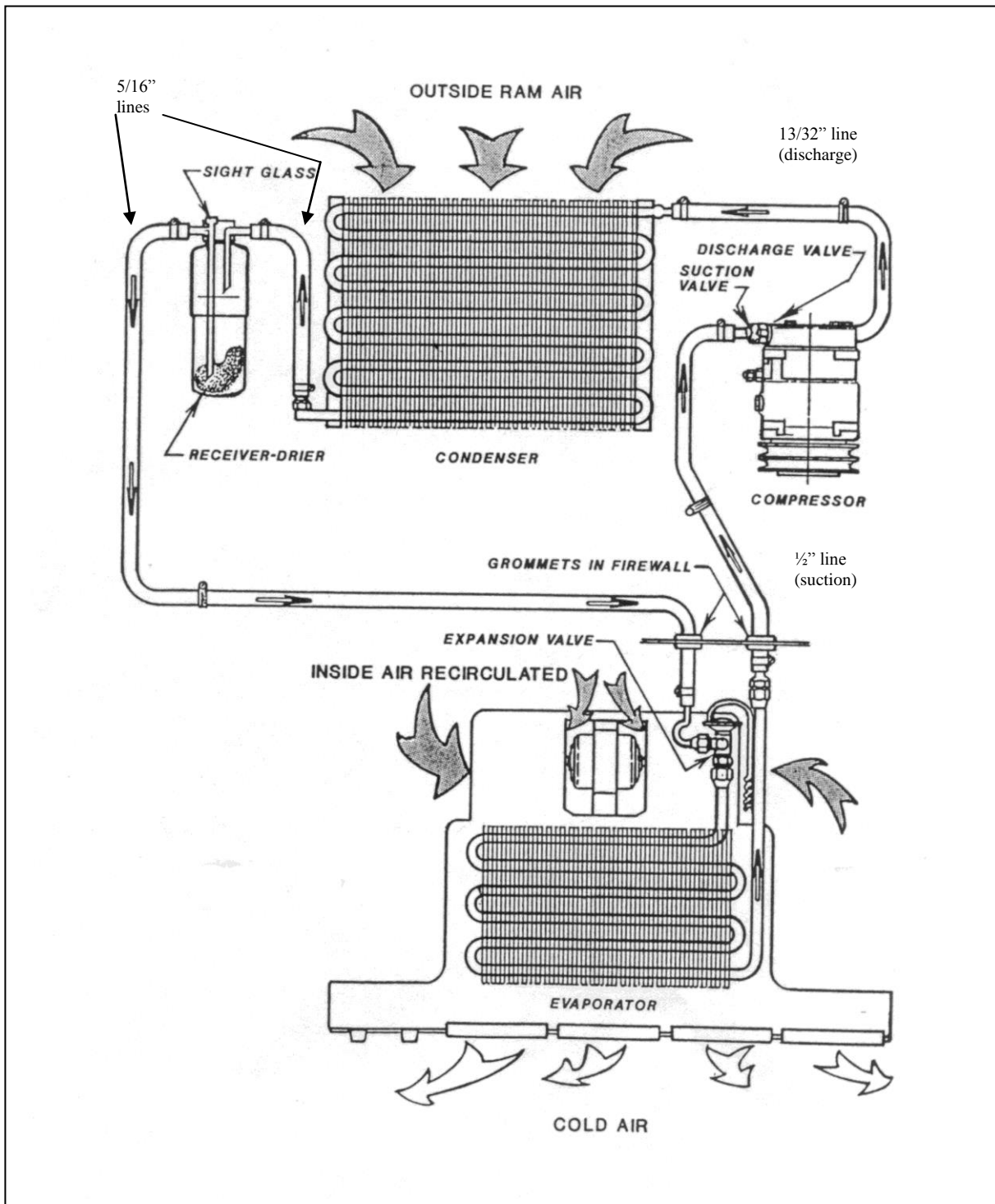

Thermostat Setting Procedures

- 1) Thermostat types
 - a) preset
 - b) adjustable
 - a) A preset thermostat is adjusted to its specific cut in and cut out temperatures when manufactured and does not have a rotary adjustment for the operator.
 - b) An adjustable or rotary thermostat has been manufactured to a predetermined cut in and cut out temperatures, but it is also operator adjustable to achieve the desired comfort level.

Both types of thermostats can have their factory settings adjusted by turning the setting screws on the body of the thermostat. One body type has the setting screws mounted externally and labeled for direction of rotation. The other body type requires the removal of the plastic end plate to expose the set screw.

- 2) Thermostat probe location: The location of the thermostat probe in an evaporator coil can be very important to achieve the maximum cooling potential of the coil while also preventing coil freeze-up. There is no set location for the thermostat probe to be put that will be optimum for all systems, but several rules of thumb may be followed:
 - a) Insert the probe in the coldest area of the evaporator coil.
 - b) Insert the probe from the top of the coil down, if possible.
 - c) Make sure that at least the last 3" of the thermostat probe are in the coil.

To find the most likely area where the coil is the coldest, consider these factors:

- 1) Direction of air flow through the coil.
 - 2) The coil area likely to have the lowest air flow.
 - 3) The inlet locations of the refrigerant into the coil.
 - 4) The inlet of the hotter outside air into the coil area.
-
- 1) Usually the coldest side of the evaporator coil will be the air outlet side. Often the thermostat probe can be inserted between the last and second last row of tubes.
 - 2) The lower air flow area of the evaporator coil in most systems tends to be near either end of the coil. These areas will be colder
 - 3) The area of the coil that the refrigerant inlet tube(s) occupy should be the coldest part of the coil.
 - 4) If the system is equipped with an outside air intake, where and how that air is brought into the evaporator area can have a large effect on the coil temperature. If all the outside air is piped into the evaporator in one area, that area will be considerably warmer in hot weather.

By looking at all these different factors, the area of an evaporator coil most likely to be the coldest can be determined.

Once the probe is inserted, the A/C system needs to be tested. Run the system to ensure that the thermostat is cycling the compressor off at the appropriate temperature. A core temperature ranging between 25° and 30° F should cause the thermostat to cycle off. The air temperature at the vent outlet closest to the evaporator coil should be between 38° F and 45° F when the compressor cycles off.

If the thermostat doesn't cycle off after a reasonable cool down period, and the air outlet temperature has dropped below 40° F, the cut in and cut out settings should be adjusted until the compressor is cycling on and off regularly. Let the system run for a decent time period (at least 15 min) and then check the evaporator coil for any signs of freezing.

Aeroquip E-Z Clip Assembly Instructions

Step 1. Cut the hose to proper length with an appropriate cutting tool. Aeroquip's hand held hose cutter has been specially designed for cutting all non-wire reinforced hose, such as GH-134 Multi-Refrigerant hose. Be sure the cut is made square to the hose length.

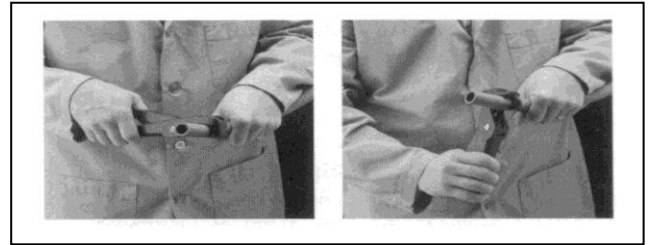

Step 2. Install two proper-sized clips onto the cut end of the hose. Orientation of the clips does not affect the performance of the connection. However, for ease of assembly, both clips should have the same orientation. NOTE: Failure to slide the clips over the hose at this time will require the clips to be stretched over the hose or fitting later. This may permanently damage the clip.

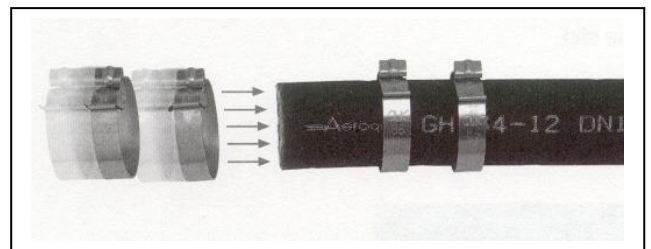

Step 3. Lubricate the nipple with a generous amount of the refrigeration or A/C system's compressor lubricating oil. This MUST be done to lower the force of nipple insertion.

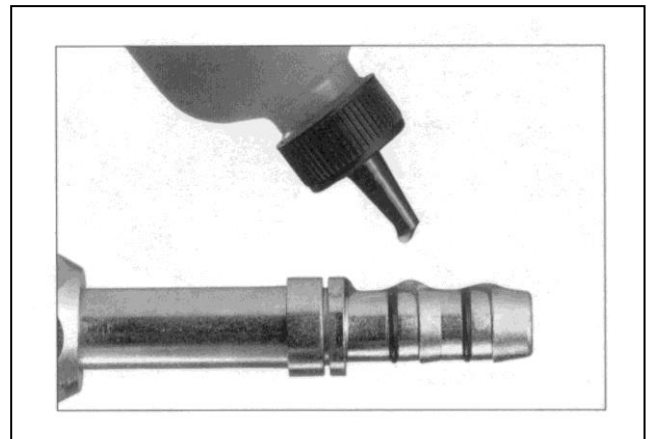

Step 4. Insert the nipple into the hose. To ensure that the nipple is fully inserted, check the gap between the cut end of the hose and the shoulder on the nipple. Care should be taken to avoid kinking or other damage to the hose during nipple insertion.



NOTE: Be sure to wipe excess oil from the nipple and hose.

Step 5. Snap the cage into the groove on the nipple. The arms should extend over the hose length. When the cage has been correctly installed in the cage groove, the cage will be able to rotate in the groove.

This step **MUST** be performed to ensure:

1. The clips will be located over the O-rings on the nipple.
2. The connection will be compatible with the connection's pressure rating.

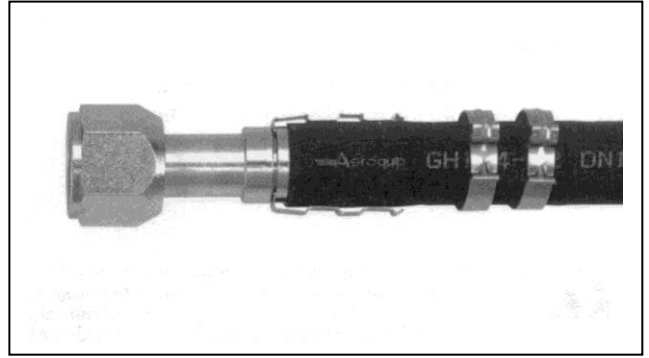

Step 6. Slide the clips over the cage arms and into the channels on each arm.

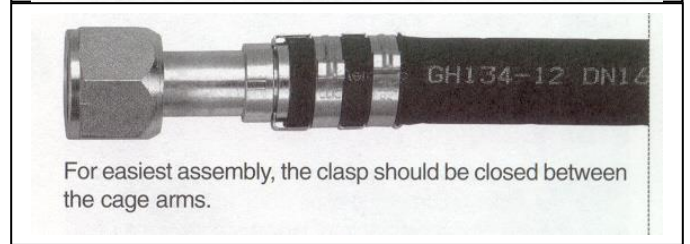
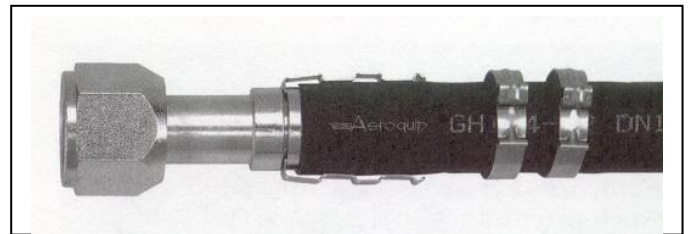

Step 7. Use the pliers to close the clips. The pliers should be positioned squarely on the clip connection points and should remain square during the closing of the clip.

NOTICE: E-Z Clip components should not be reused.

